

Bolt Anchor

Approval no.: ETA-18/0542, with nut and large washer

DAZ 10X10

EAN Code: 4013339842827
Smallest packaging unit:50 pcs.

the photorealistic images are to be considered as reference images

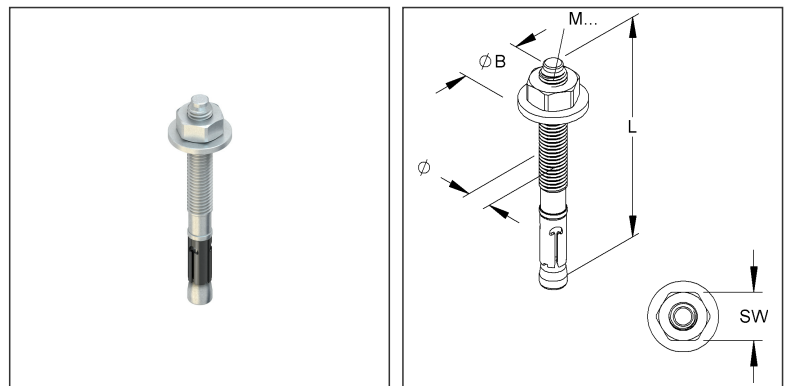

Article Description

Anchor bolt, large washer, theard M10, max. length 10 mm, steel, electro galvanised according to DIN EN ISO 2081/4042, incl. nut

Additional Price Information

Article group	N19
quantity unit	pcs.

Weight

Weight per quantity unit	64 g / pcs.
Weight in kg per 100	6,33 kg / 100pcs.

Technical Datasheet

Dowels

DAZ 10X10

the photorealistic images are to be considered as reference images

Physical Article Dimensions

Height	25.00 mm
Width	25.00 mm
Depth/length	96.50 mm

Packing Dimension

50 pieces = 1		✓ VP1-smallest packaging unit (PU)		✓ VP1-preferred PU	
Lenght	285 mm	Width	90.00 mm	Height	90.00 mm
Gross weight	3,16 kg	Volume	0,002 m ³		
Min. quantity	50.00 pcs.	Max. Quantity	50.00 pcs.		

6800 pieces = 1 pallet					
Lenght	1200 mm	Width	510 mm	Height	800 mm
Gross weight	445 kg	Volume	0,490 m ³		
Min. Quantity	6.800.00 pcs.	Max. Quantity	6.800.00 pcs.		

Tender Text

Anchor bolt with metric connection thread M 10, including galvanised nut and large washer. For outdoor use, we recommend stainless steel push-through anchors! For use in functional maintenance or for suspended ceilings with fire protection requirements (Model Laying System Guideline MLAR 2/2015), please observe additional regulations!

Application: The number and arrangement of the push-through anchors must be taken from the implementation planning or the structural analysis and must be complied with. Installation and assembly acc. to European Technical Assessment ETA-18/0542 or assembly instructions in cracked and non-cracked concrete C20/25 to C50/60. For dimensioning, the entire approval notice ETA-18/0542 and the approvals mentioned below must be observed. Use in dry interior rooms.

Technical data

Connection thread : M 10

Total length L : 95 mm

Nominal bore Ø : 10 mm

Washer Ø : 25 mm

Clamping range t fix : ≤ 10 mm

Effective anchorage depth h ef : 60 mm

Recommended torque : 45 Nm

Width across flats : 17/16

Material : electro galvanised according to DIN EN ISO 19598/4042, blue passivated

Approval no. : ETA-18/0542

DoP NI003

NIEDAX Model no. : DAZ 10X10

EP Material _____ EP Wage _____

Unit price/piece

Safety & Environment

REACH Date	04.02.2026
REACH Info	Conformable
RoHS Info	Conformable

Technical Datasheet

Dowels

DAZ 10X10

the photorealistic images are to be considered as reference images

Origin & International Trade

Country of origin	DE
Customs tariff number	73181900